

System 25

Laser Diode LIV Test System Kit



Shown: S25-22224 fully assembled and installed in optional 8000-10 equipment rack (laser diode module not included)

- Programmable LIV test system for laser diode modules
- Sweep and measure 400 points in <8s
- Very low noise current source (50 μ A) for laser diode drive
- Up to 5A laser diode drive current
- Measures optical power directly
- 1fA resolution for dark current measurements
- Fully digital P-I-D loop for temperature control
- $\pm 0.005^\circ\text{C}$ temperature stability, $\pm 0.001^\circ\text{C}$ setpoint resolution
- Trigger Link, source memory, and buffer memory support automatic test sequencing, which greatly reduces GPIB bus traffic to improve test throughput
- Expandable and flexible for future requirements

Complete DC Test System with Temperature Control

Keithley's LIV (light-current-voltage) Test System Kit is designed to help manufacturers of laser diode modules (LDMs) keep pace with production demands by allowing them to boost yield and throughput. The LIV test system combines all the DC measurement capabilities required to test these modules with optical power measurement and tight temperature control over the device under test in an integrated instrument package. The LIV test system is configured from proven Keithley instrumentation; the basic configuration can be easily modified to add new measurement functions or to allow for new connections.

Tight Integration Ensures Higher Test Speeds

The LIV test system allows for fast, easy integration and high test speeds because all the building blocks come from the same supplier. All newer Keithley instruments include the Trigger Link feature and digital I/O lines, as well as standard IEEE-488 (GPIB) and RS-232 interfaces, to speed and simplify system integration and control. The Trigger Link feature combines independent software selectable trigger lines on a single connector for simple, direct control over all instruments in a system without the need for constant traffic over the GPIB. This feature is particularly useful for reducing total test time if the test involves a sweep. The digital I/O lines simplify external handler control and binning operations.

Source memory and buffer memory, provided by Models 2400-IV, 2420, 2440, and 2502, enable elimination of GPIB traffic during sweep testing. Source memory is a built-in "programmable test sequencer" for configuring up to 100 different tests. The buffer memory stores data that can be downloaded to the PC via the GPIB after an LIV test sweep is complete. Source memory, buffer memory, and Trigger Link work in concert to form an autonomous test system—all it takes to begin the test sequence is a "start of test" command from the PC. Benchmark testing has demonstrated that these features allow the system to complete a 400-point LIV test sweep with data transfer to the PC in less than eight seconds.

Easy to Program, Easy to Use

Each kit comes complete with the necessary cables and hardware to use the system. Having all the instrumentation supplied by the same vendor simplifies system programming and improves ease of use. All instruments in the standard system respond to the same SCPI command structure. LabVIEW and Visual instrument drivers and demonstration software are also available to simplify application development.

Flexible System Configuration Options

In addition to the standard system configurations, LIV test systems can be customized to accommodate virtually any test sequence or setup requirement. Adding new capabilities or expanding existing ones is as simple as adding a new Keithley instrument or switch system. For example, to add isolation resistance measurements, just include any of Keithley's Series 2000 Digital Multimeters in the configuration.

To accommodate multiple pin-out schemes, choose a Series 7000 Switch Mainframe and plug in one or more switch cards, such as the Model 7012 4 \times 10 Matrix Card or the Model 7053 High Current Scanner Card for switching up to 5A. Automated switching makes it simple to accommodate future pin-out configuration changes.

A custom configuration and ordering guide is available to simplify selecting all the critical items needed to complete a system.

1.888.KEITHLEY (U.S. only)

www.keithley.com

KEITHLEY

A GREATER MEASURE OF CONFIDENCE

System 25

Laser Diode LIV Test System Kit

Single Vendor Solution

In addition to the assurance of hardware and software compatibility, systems integrators can be confident they'll get all the technical support they need to complete and maintain their systems from a single source. Keithley's applications engineers can help systems integrators optimize the performance of each instrument in the system to ensure high speed and accuracy from the system as a whole.

High Accuracy Building Blocks

The standard LIV test system provides a fast, flexible solution for testing LDMs by combining the functions of several high speed, high accuracy Keithley instruments:

- **Model 2400-IV, 2420, or 2440 High Current SourceMeter instrument.** During LIV testing, the SourceMeter instrument provides a current sweep to drive the laser diode. It also synchronizes the measurements made by other instruments in the system. The Model 2400-IV, 2420, and 2440 SourceMeter instruments are part of Keithley's SourceMeter family and were developed specifically for test applications that demand tightly coupled precision voltage and current sourcing and measurement. Selecting the instrument's high current range eliminates the potential for range change glitches if currents higher than 1A are needed during the LIV sweep. The Model 2420 offers drive current of up to 3A. The Model 2440 offers up to 5A of drive current for demanding pump laser control.
- **Model 2502 Dual Photodiode Meter.** The Model 2502 measures the current flow in the back facet photo detector and combines with the Model 2500INT Integrating Sphere to directly measure optical power. Both optical power measurement channels are fully independent. The measurement timing circuitry is shared between both channels to provide simultaneous measurements to optimize LIV performance. Each channel has eight measurement ranges and provides a resolution high enough to measure dark currents of the photodiode. The isolated bias sources provide up to 100V of bias. The Model 2502 has a high speed analog output that allows the LIV system to be combined with a fiber alignment system.
- **Model 2510-AT TEC SourceMeter instrument.** The Model 2510-AT is a 50W bipolar instrument that controls the operation of an LDM's Thermo-Electric Cooler or TEC (sometimes called a "Peltier device") during LIV testing. During testing, the Model 2510-AT measures the internal temperature of the LDM from any of a variety of temperature sensors, then drives power through the TEC in order to maintain the LDM's temperature at the desired setpoint.

The Model 2510-AT's software-based, fully digital P-I-D (proportional-integral-differential) control provides excellent temperature stability. This high stability allows for very fine control over the output wavelength and over the optical power of the LDM during testing. Another Model 2510-AT can be added to include ambient fixture control, if the test will be done under a variety of ambient conditions. The instrument includes a low-level TEC resistance measurement function to check TECs for mechanical damage during module assembly.

The Model 2510-AT offers autotuning capability. P, I, and D (proportional, integral, and derivative) values for closed loop temperature control are determined by the instrument using a modified Zeigler-Nichols algorithm. This eliminates the need for users to experiment by inputting various P, I, and D coefficients repeatedly in order to determine the optimal values.

- **Model 2500INT Integrating Sphere.** This accessory for the Model 2502 accepts direct optical input and provides for accurate L measurement without being sensitive to polarization mode or beam profile at the end of the fiber. The integrating sphere is available with a silicon, germanium, or cooled indium gallium arsenide detector to ensure accurate optical power measurements at any wavelength.
- **Model 854x.** The 854x Laser Diode Mount Series makes it easier than ever to configure a complete laser diode LIV test system for continuous wave test applications. These fixtures provide highly stable temperature control for all telecommunications laser diodes. They offer an easy-to-use platform for testing laser diodes used in telecommunications. They are designed to speed and simplify setting up test systems for all laser diode/photodiode/thermoelectric cooler/thermistor configurations.

For additional information on any of the building blocks of the LIV test system, refer to the data sheet for that instrument.

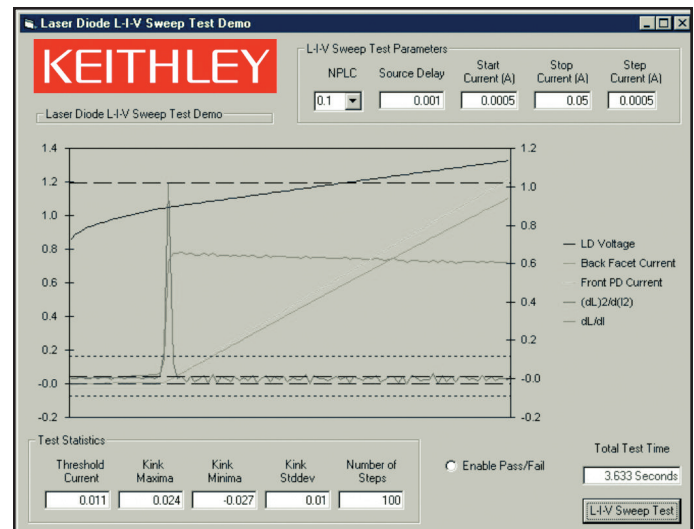

A demonstration software package, written in Visual Basic, is available with the LIV test system to give programmers a head start on creating their own applications. Using the demonstration package, users can set a variety of test parameters, including NPLC (integration time), Source Delay (settling time before measurement), Start Current, Stop Current, and Step Current. These parameters allow users to define the current sweep range and make speed and accuracy trade-offs by adjusting Source Delay and NPLC. The resulting data can be analyzed to determine threshold current and kink statistics. The total test time includes the instrument setup, LIV sweep, and data transfer times (but not the computation times).

1.888.KEITHLEY (U.S. only)

www.keithley.com

KEITHLEY

A GREATER MEASURE OF CONFIDENCE

System 25

Laser Diode LIV Test System Kit

Ordering Information

S25- [] [] [] []

Source/Measure

0	2400-LV/2502	General Purpose
2	2420/2502	Transmitter/Pump
4	2440/2502	Pump Laser

Temperature Control

0	None	
1	2510-AT	Single Temp. Control
2	2510-AT/2510-AT	Dual Temp. Control

Integrating Spheres

00	None	
21	2500INT-2-SI	2" Sphere, Silicon
22	2500INT-2-GE	2" Sphere, Germanium
23	2500INT-2-IGAC	2" Sphere, Cooled InGaAs

Laser Diode Mounts

0	None	
2	8542	14-Pin DIL Mount
4	8544	14-Pin Butterfly Mount
4t	8544-TEC	14-Pin Butterfly w/TEC Control

Select the instrument and accessory for your application. Review the detailed specifications of each instrument in individual catalog sections.

ACCESSORIES INCLUDED IN EACH OPTION

SOURCE/MEASURE

Includes: 2400-LV, 2420, or 2440 SourceMeter Instrument
2502 Photodiode Meter
(2) GPIB Interface Cables
Trigger Link Cable
Integrating Sphere Cable and adapter (Triax, 6172 adapter)
DUT Cables (terminated in Alligator clips)
Rackmount Conversion Kit

TEMPERATURE CONTROL

Includes: 2510-AT SourceMeter Instrument(s)
GPIB Interface Cable(s)
DUT Cables
Rackmount Conversion Kit

INTEGRATING SPHERE

Includes: 2500INT Integrating Sphere
1/2" open input port
Post Stand

LASER DIODE MOUNT

Includes: 854x Laser Diode Mount
Easy Connect Multi Terminated Laser Diode Cables
Easy Connect Multi Terminated Temperature Cables

CUSTOM SYSTEMS

Custom systems are available. Contact your local Keithley sales person.

ASSEMBLY SERVICES

The S25 Systems are not assembled. If you would like assembly service, contact your local Keithley salesperson.

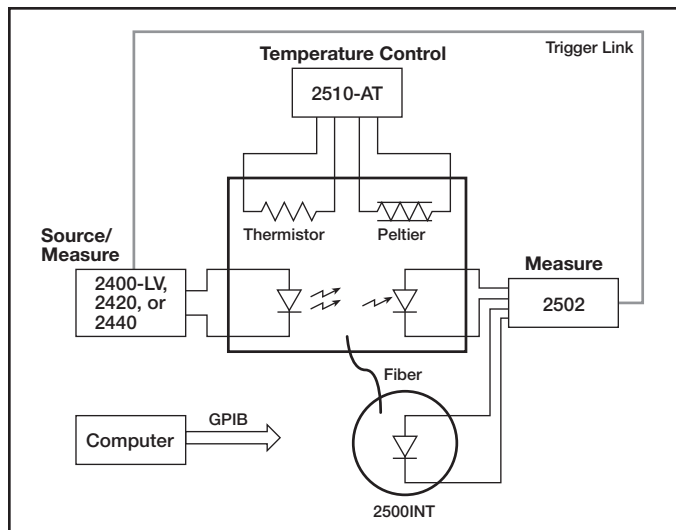

Figure 1. The standard LIV test system is designed for applications that require the highest measurement accuracy. The Model 2420 SourceMeter drives the laser diode, sweeping the drive current from 0A up to 3A in programmable steps. At each step in the sweep, the Model 2420 records the current and voltage measurements, while the Model 2502 measures and records the current flow in the photodiodes. When the sweep is complete, the raw measurement data from the Model 2420 and the Model 2502 is uploaded to the PC for analysis. The LIV Demo Software can calculate first and second derivatives of the back facet monitor diode or the external photo detector.

ACCESSORIES AVAILABLE

FIBER ADAPTERS

(System kit has a 1/2" input port. For fiber input add adapter below.)
2500INT-FC/APC FC/APC Fiber Adapter to Integrating Sphere
2500INT-FC/PC FC/PC Fiber Adapter to Integrating Sphere
2500INT-SMA SMA Fiber Adapter to Integrating Sphere

CABINETS

(System kit is supplied with all necessary rack mount hardware. Purchase appropriate cabinet and assembly services separately.)

8000-10 Equipment Cabinet 10" high (holds 4 instruments)
8000-14A Equipment Cabinet 14" high
8000-17A Equipment Cabinet 17.5" high

GPIB CARDS

(GPIB communication required for complete LIV capabilities.)
KCI-488 IEEE-488.2 PCI interface Card

1.888.KEITHLEY (U.S. only)

www.keithley.com

KEITHLEY

A GREATER MEASURE OF CONFIDENCE